

Cover plate removed for clarity. Refer to exploded view of assembly on page 6-7 to identify item number and parts.

Degrease fifth wheel before installing new parts

1. Set the fifth wheel in the closed position

To set the fifth wheel in the closed position, rotate the jaw towards the front of the fifth wheel with a screw driver of adequate length to keep hands and fingers out of the throat of the wheel. This will partially close the wheel. Now pull out on the pull handle a small amount and complete the rotation of the jaw toward the front of the wheel. Allow the pull handle to go in slowly for the wheel to completely close.

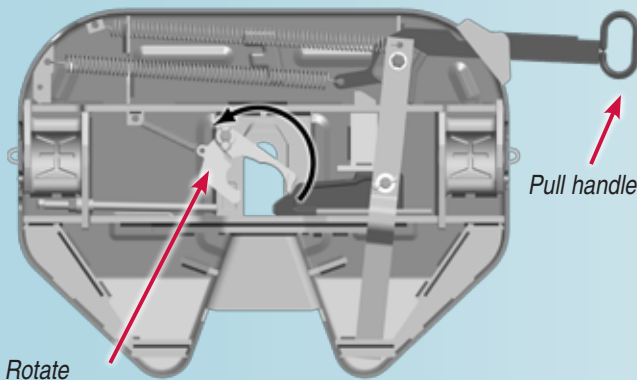

Rotate jaw counter-clockwise toward the front of wheel

2. Remove the jaw spring

Remove the jaw spring (item 27). Now remove the main spring (item 26) from the pull handle. Remove the main spring (item 26) from the operating handle.

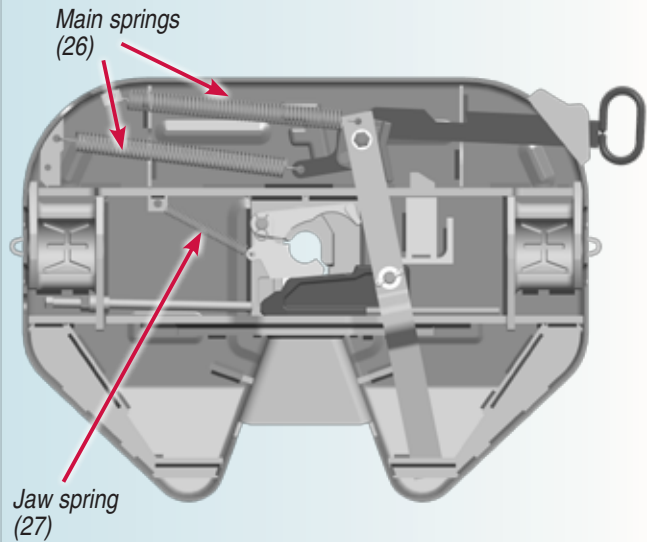

3. Remove the lock nut, flat washer, spacer and hex nut

Remove the 5/8"-11 lock nut, flat washer and spacer (items 25, 24, 23) and 5/8"-11 hex head bolt (item 19) which secures the secondary lock latch (item 21) to the operating handle (item 31). Hex head bolt is captured inside the secondary lock.

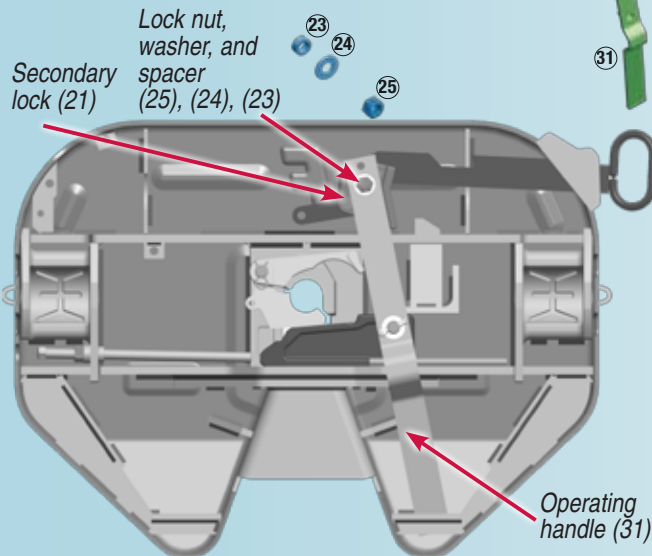

Secondary lock (21)

Lock nut, washer, and spacer (25), (24), (23)

Operating handle (31)

4. Remove the pivot pin clip/pin

Remove the cotter pin (item 33) from the pivot pin (item 20) and washer (item 32) which attaches the operating handle (item 31) to the locking wedge (item 30).

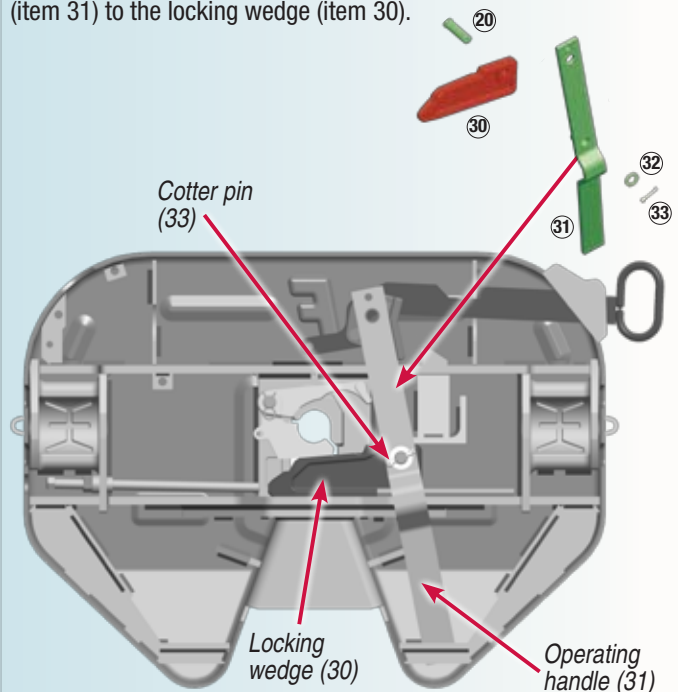

Cotter pin (33)

Locking wedge (30)

Operating handle (31)

Cover plate removed for clarity. Refer to exploded view of assembly on page 6-7 to identify item number and parts.

5. Remove the operating handle and locking wedge

Remove the operating handle (item 31) and locking wedge (item 30) by pulling the operating handle to the open position. This will allow you to remove the operating handle from the wedge. Remove the wedge (item 30) and short pivot pin (item 20). Turn the adjustment rod (item 1) counter clockwise (outward) until it has moved about two inches from starting position. This will eliminate interference when removing and installing the locking jaw.

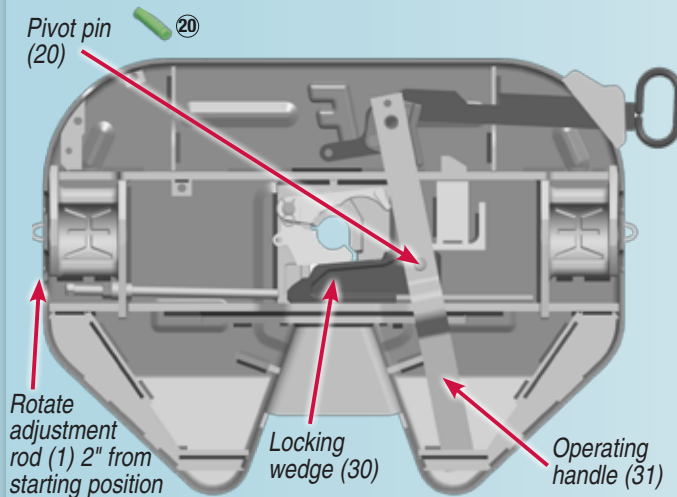

6. Remove the pull handle and secondary lock.

Remove the 1/2" hex head bolt, spacer bushing, washer and lock nut (items 15, 16, 17 & 22) which secures the secondary lock latch (item 21) to the pull handle. Remove the pull handle and secondary lock.

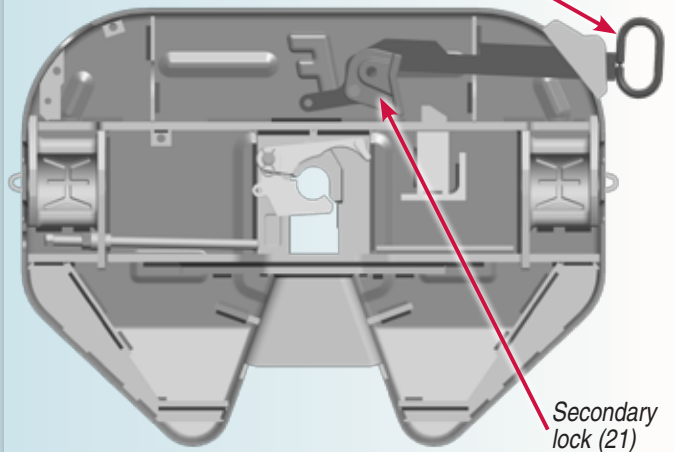

7. Remove the rotating locking jaw

Remove the pivot pin clip (item 29) from the long pivot pin (item 7). Raise the top plate and remove the long pivot pin (item 7) that secures the rotating locking jaw (item 28). Remove the rotating locking jaw.

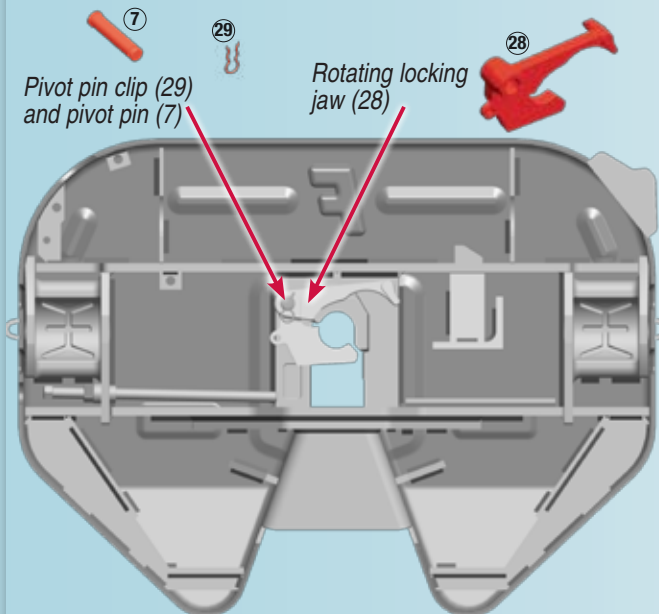

Refer to exploded view of assembly on page 6-7 to identify item number and parts.

Adequate lubrication should be used

1. Insert rotating locking jaw

Insert the rotating jaw (item 28) after applying a light coating of grease. Note: Insert the jaw so that the hole in the cover plate lines up with the hole in the rotating jaw. Raise the fifth wheel and then insert the long pivot pin (item 7) into the fifth wheel and then into the rotating jaw. Note: Make sure the notched portion of the pivot pin is inserted into the fifth wheel first. Secure the pivot pin in place with a new pivot pin clip (item 29).

Rotating locking jaw (28)

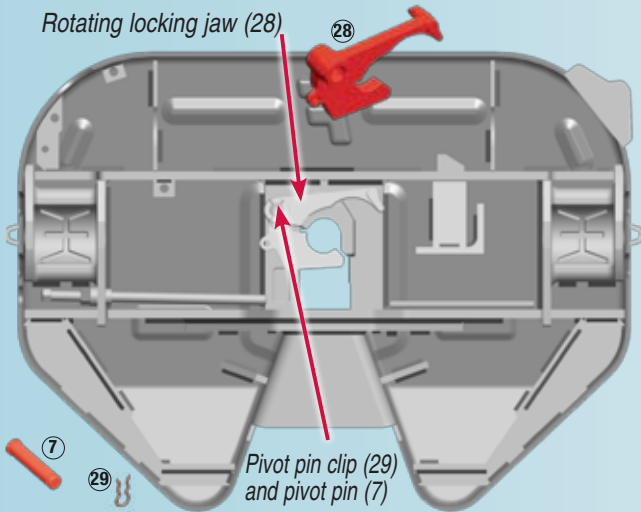

2. Insert the pull handle and secondary lock

Insert the pull handle. After applying a light coat of grease to the pivot points, insert the secondary lock latch (item 21) into the fifth wheel. Attach the pull handle to the secondary lock latch using the 1/2" hex head bolt, spacer bushing, washer and new lock nut (items 15, 16, 17 & 22).

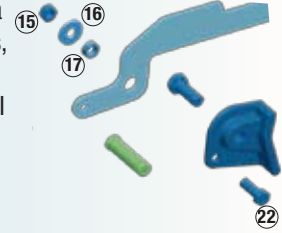

Pull handle (18)

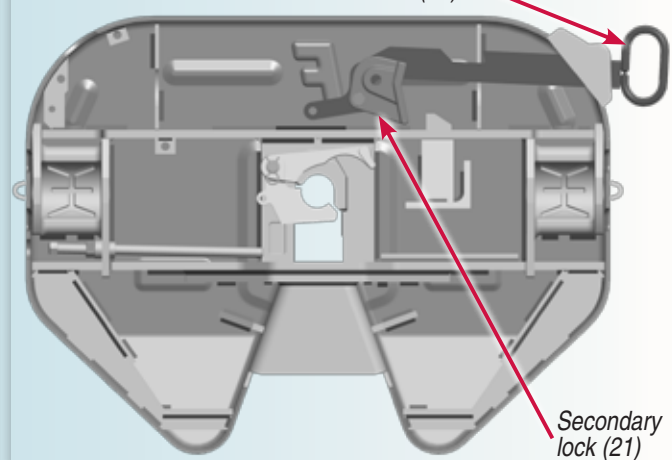

3. Insert wedge, and handle

Insert the new short pivot pin (item 20) into the locking wedge (item 30) after applying a light coat of grease. Insert the locking wedge into the wheel. Move the locking wedge in behind the rotating locking jaw (item 28) to verify operation. Now slide the locking wedge back toward the outside of the wheel. This will assist in installing the operating handle (item 31) into the slot at the bottom of the fifth wheel and over the locking wedge pivot pin. Rotate the operating handle towards the center of the fifth wheel. This will slide the locking wedge behind the locking jaw.

Rotating locking jaw (28)

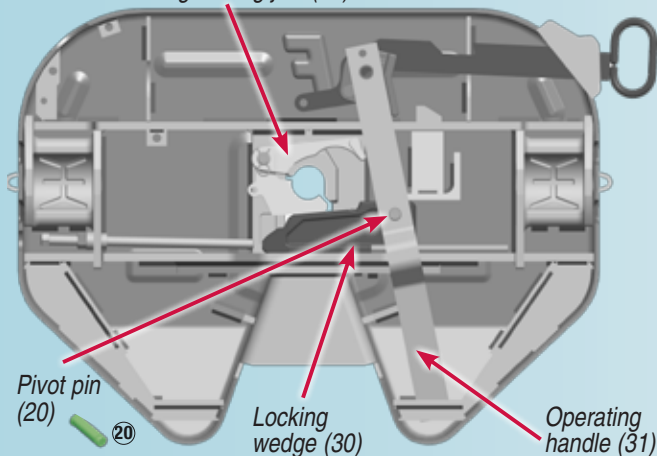

Before rebuilding the assembly, check to make sure that there are no cracks in the crossmembers or other components. Also check bracket pin holes to ensure they are not overly worn (pins should fit snugly). Refer to exploded view of assembly on page 6-7 to identify item numbers and parts.

Refer to exploded view of assembly on page 6-7 to identify item number and parts.

4. Attach the operating handle to the locking wedge

Attach the operating handle (item 31) to the locking wedge using a cotter pin (item 33) and washer (item 32) to secure the connection.

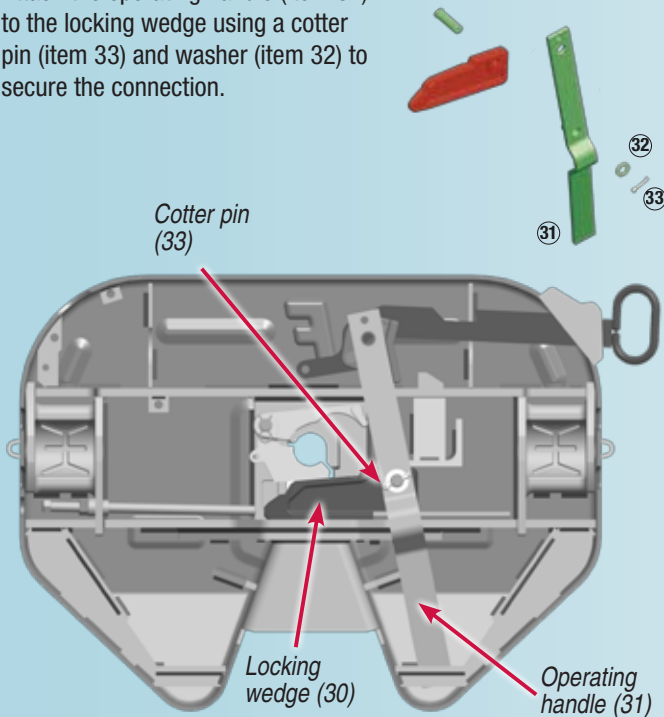

5. Attach the secondary lock latch to the operating handle

Attach the secondary lock latch (item 21) to the operating handle (item 31) using the 5/8"-11 hex head bolt (item 19) and new lock nut (item 25) with flat washer and spacer (items 24 & 23).

Note the orientation of the bolt (item 19) the threads should be facing up.

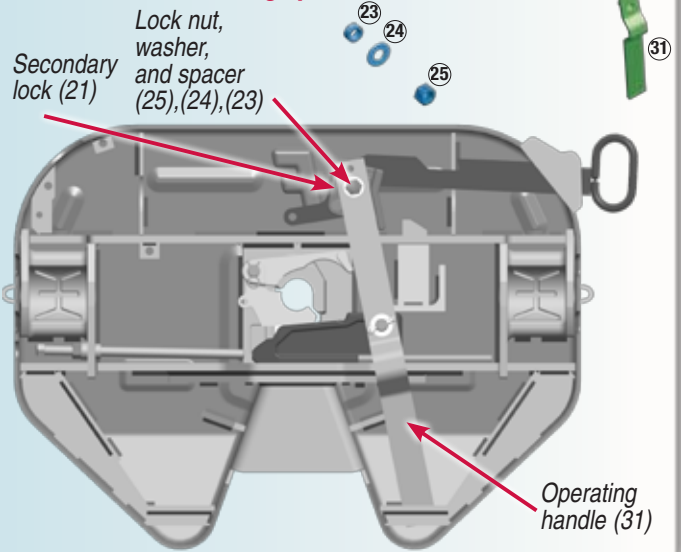

6. Attach springs

Make sure the fifth wheel is completely closed. Attach the jaw spring (item 27) to the rotating locking jaw. Now install main spring (item 26) to the pull handle. Now install the main spring (item 26) to the operating handle.

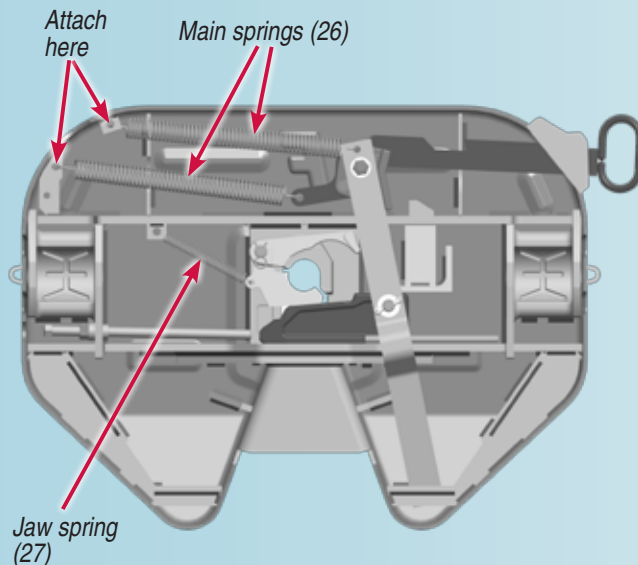

7. Adjust fifth wheel

Open the fifth wheel, insert a 2" kingpin and close the wheel. Turn the adjustment rod (item 1) clockwise (inward) until it contacts the end of the locking wedge. Now turn the adjustment rod clockwise (inward) an additional 2-1/2 complete revolutions. This will give the recommended 0.525 mm (.02") running clearance. Tighten the adjuster rod jam nut (item 2). The fifth wheel should operate freely and smoothly without binding or interference.

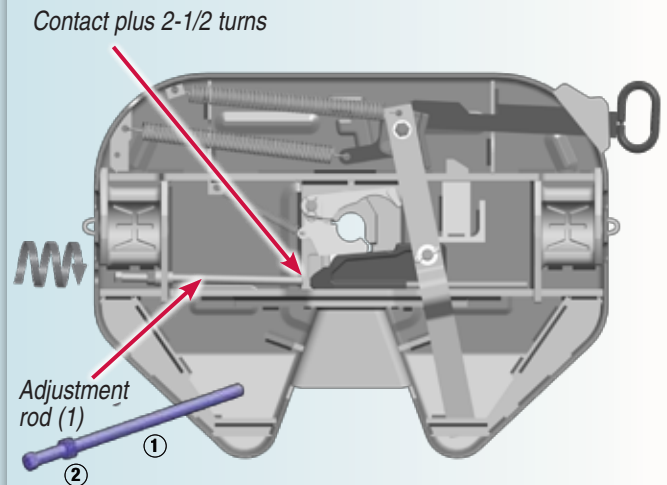

Ultra LT rebuild diagram

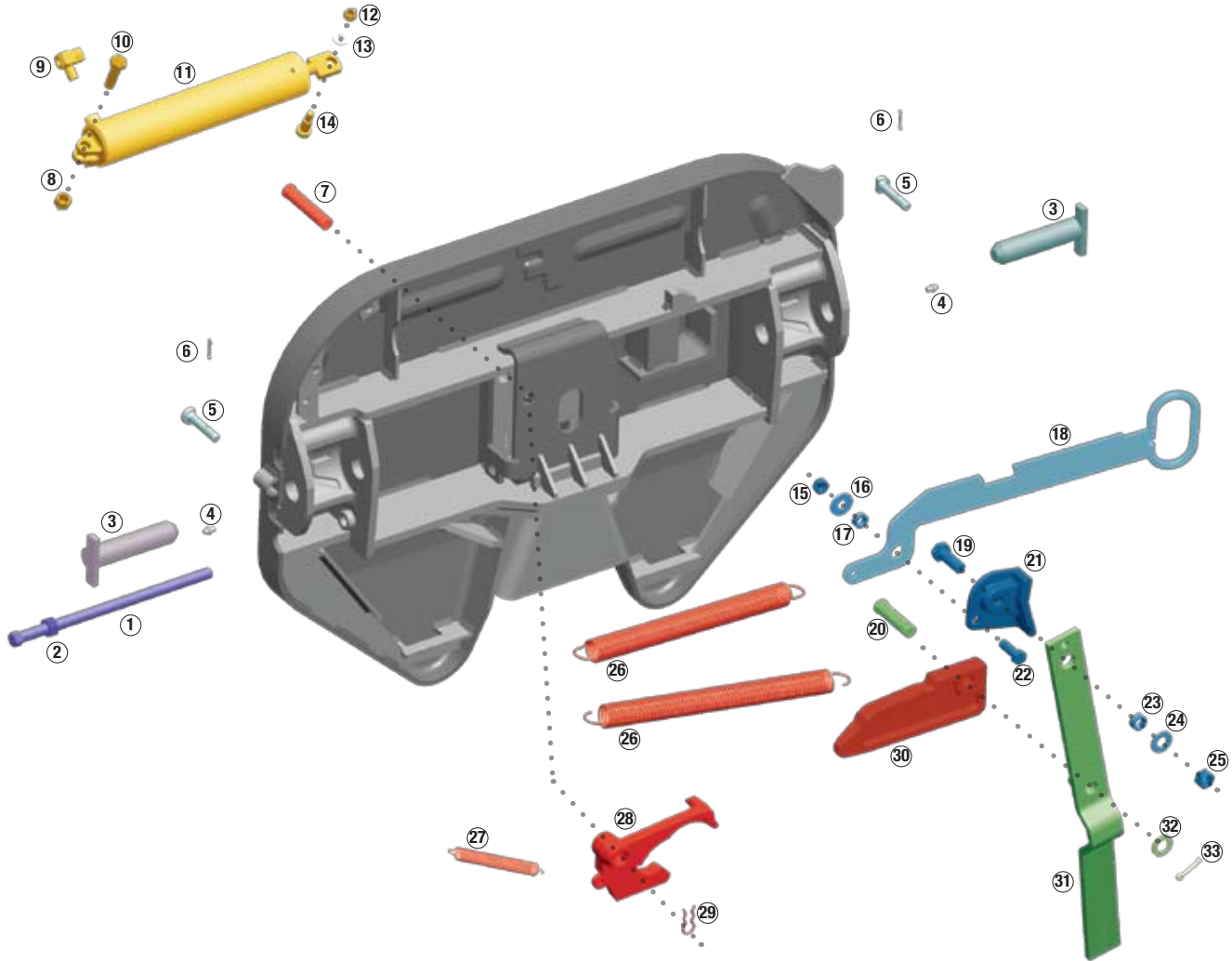

Repair kit (KIT-RPR-ULTL)		
Item	Description	Quantity
7	Pivot pin, long	1
20	Pivot pin, short	1
25	Lock nut, 5/8"-11	1
26	Main spring	2
27	Jaw spring	1
28	Rotating locking jaw	1
29	Pivot pin clip	2
30	Locking wedge	1
32	Washer, 3/4"	1
33	Cotter Pin	1

Spring kit (KIT-SPR-ULT)		
Item	Description	Quantity
26	Main spring	2
27	Jaw spring	1

Adjuster rod kit (KIT-ROD-ULT)		
Item	Description	Quantity
1	Adjustment rod	1
2	Adjustment rod nut	1

Secondary lock kit (KIT-SEC-ULTL)		
Item	Description	Quantity
15	Lock nut, 1/2"-13	1
16	Washer, 1/2"	1
17	Bushing, 5/16"	1
19	Hex head bolt, 5/8"-11 x 1.75"	1
21	Secondary lock	1
22	Hex head bolt, 1/2"-13 x 1.5"	1
23	Spacer bushing	1
24	Washer, flat 5/8"	1
25	Lock nut, 5/8"-11	1

Operating lever kit (KIT-OPR-ULTL)		
Item	Description	Quantity
19	Hex head bolt, 5/8"-11 x 1.75"	1
20	Pivot pin, short	1
23	Spacer bushing	1
24	Washer, flat 5/8"	1
25	Lock nut, 5/8"-11	1
31	Operating handle	1
32	Washer, 3/4"	1
33	Cotter Pin	1

Air cylinder kit (KIT-AA-ULTL)		
Item	Description	Quantity
8	Lock nut, 1/2"-13	1
9	Exhaust valve	1
	Quick disconnect (not pictured)	1
10	Hex head bolt, 1/2"-13 x 1.75"	1
11	Air cylinder	1
12	Lock nut, 3/8"-16	1
13	Washer, 3/8"	1
14	Shoulder bolt, 3/8"-16	1
26	Main spring	1

Mounting pin kit (KIT-PIN-ULT)		
Item	Description	Quantity
3	Bracket pin	2
5	Bracket retainer pin	2
6	Cotter pin	2
	Bracket bushing (not pictured)	2

Pull handle kit (KIT-PUL-ULTL)		
Item	Description	Quantity
15	Lock nut, 1/2"-13	1
16	Washer, 1/2"	1
17	Bushing, 5/16"	1
18	Pull handle	1
22	Hex head bolt, 1/2"-13 x 1.5"	1



Ultra LT rebuild diagram key

Item	Description	Quantity
①	Adjustment rod	1
②	Adjustment rod nut	1
③	Bracket pin	2
④	Grease fitting	2
⑤	Bracket retainer pin	2
⑥	Cotter pin	2
	Bracket bushing (not pictured)	2
⑦	Pivot pin, long	1
⑧	Lock nut, 1/2"-13	1
⑨	Exhaust valve	1
	Quick disconnect (not pictured)	1
⑩	Hex head bolt, 1/2"-13 x 1.75"	1
⑪	Air cylinder	1
⑫	Lock nut, 3/8"-16	1
⑬	Washer, 3/8"	1
⑭	Shoulder bolt, 3/8"-16	1
⑮	Lock nut, 1/2"-13	1
⑯	Washer, 1/2"	1
⑰	Bushing, 5/16"	1
⑱	Pull handle	1
⑲	Hex head bolt, 5/8"-11 x 1.75"	1
⑳	Pivot pin, short	1
㉑	Secondary lock	1
㉒	Hex head bolt, 1/2"-13 x 1.5"	1
㉓	Spacer bushing	1
㉔	Washer, flat 5/8"	1
㉕	Lock nut, 5/8"-11	1
㉖	Main spring	1
㉗	Jaw spring	1
㉘	Rotating locking jaw	1
㉙	Pivot pin clip	1
㉚	Locking wedge	1
㉛	Operating handle	1
㉜	Washer, 3/4"	1
㉝	Cotter Pin	1



Fontaine Parts Connection • 7574 Commerce Circle • Trussville, AL 35173
800-874-9780 • Fax: 205-655-9982

www.fifthwheel.com