

Fontaine Fifth Wheel Ultra LT

Product Enhancement Instructions



FONTAINE®
PARTS CONNECTION

www.fifthwheel.com • 800-874-9780

Before starting the rework

- Review the rework kit contents
The kit will include:
 - (1) Locking wedge (item 30)
 - (1) 5/8" locknut (item 25)
 - (1) 1/4" x 1-1/2" cotter pin (item 33)
 - (1) 3/4" flat washer (item 34)
 - (2) 3/16" x 1" cotter pins (item 6)
- Acquire the necessary tools
 - Ratchet
 - 3/4" socket
 - 15/16" socket and wrench
 - Pliers
 - Large flat screwdriver or pry bar
 - Hammer
- Remove the fifth wheel from the lower mount assembly so that the underside is accessible.

Rework kit items shown in red boxes

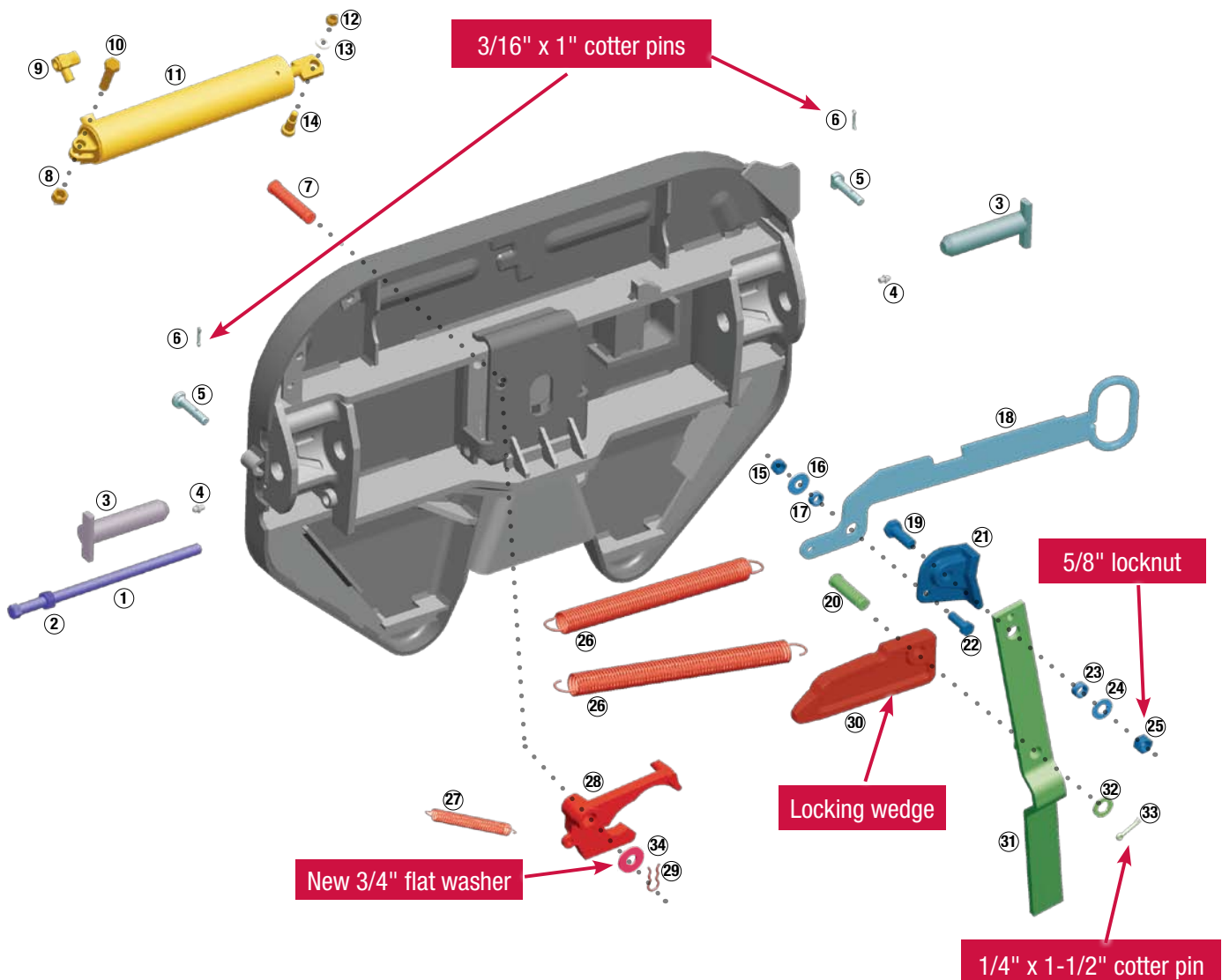

Cover plate removed for clarity. Refer to exploded view of assembly on page 2 to identify item number and parts.

Degrease fifth wheel before installing new parts

1. Set the fifth wheel in the closed position

To set the fifth wheel in the closed position, rotate the jaw towards the front of the fifth wheel with a screw driver of adequate length to keep hands and fingers out of the throat of the wheel. This will partially close the wheel. Now pull out on the pull handle a small amount and complete the rotation of the jaw toward the front of the wheel. Allow the pull handle to go in slowly for the wheel to completely close.

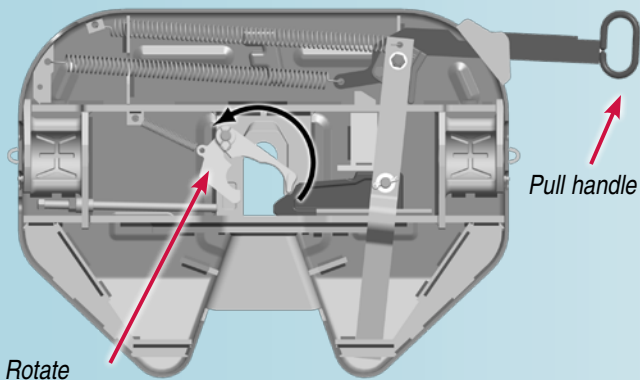

Rotate jaw counter-clockwise toward the front of wheel

2. Remove the springs

Remove the jaw spring (item 27). Remove the main spring (item 26) from the pull handle. Remove the main spring (item 26) from the operating handle.

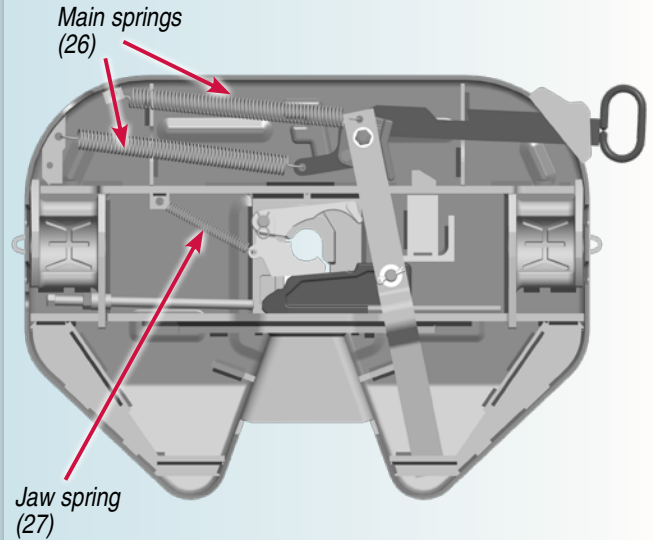

3. Remove the lock nut from the operating handle

Remove and discard the 5/8"-11 (item 25) lock nut which secures the secondary lock (item 21) to the operating handle (item 31). The hex head bolt (item 19) is captured inside the secondary lock (item 21). Reuse the bolt, washer and spacer (item 19, 23 and 24).

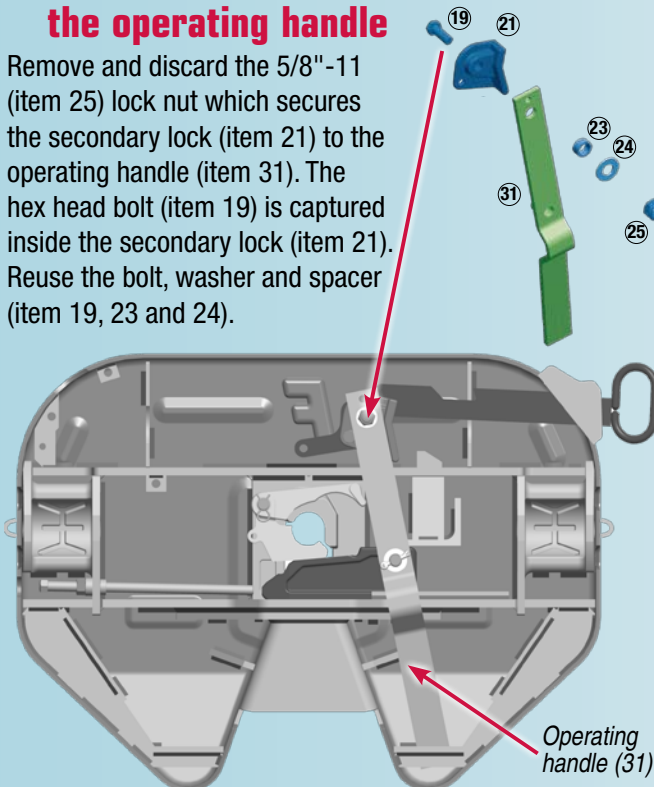

4. Remove the wedge pivot pin and cotter pin

Remove the cotter pin (item 33) and washer (item 32) from the wedge pivot pin (item 20) which attaches the operating handle (item 31) to the locking wedge (item 30). Discard the cotter pin.

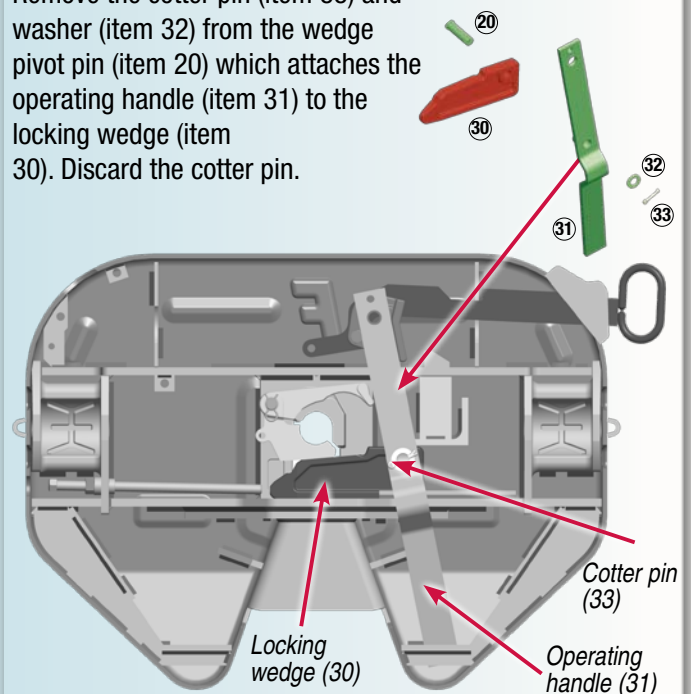

Cover plate removed for clarity. Refer to exploded view of assembly on page 2 to identify item number and parts.

5. Remove the operating handle and locking wedge

Pull the operating handle (item 31) to the open position. This will allow you to remove the operating handle from the wedge. Remove the wedge (item 30) and wedge pivot pin (item 20). Loosen the adjustment rod jam nut (item 2) and turn the adjustment rod (item 1) counter clockwise (outward) until it has moved about two inches from starting position. This will eliminate interference when installing the new locking wedge.

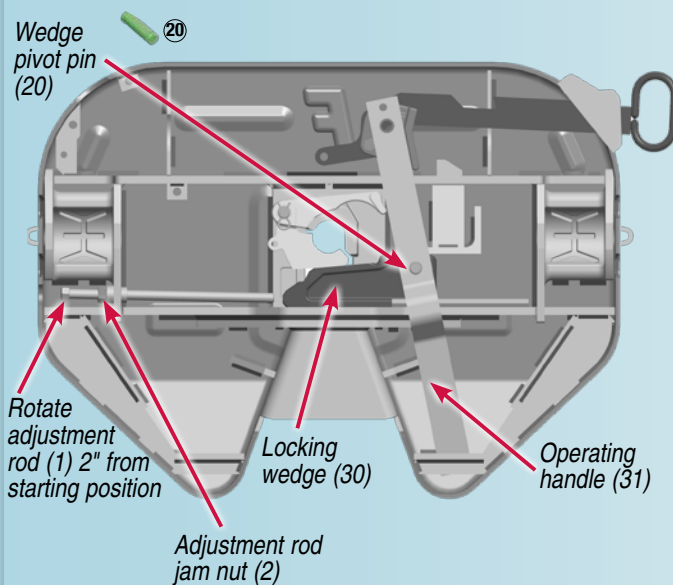

6. Loosen the rotating locking jaw pivot pin

Remove the pivot pin clip (item 29) from the long pivot pin (item 7). Raise the top plate and slide the long pivot pin (item 7) that secures the rotating locking jaw (item 28) out far enough to assemble the provided washer between the rotating jaw and cover plate as described in step one of the assembly instructions.

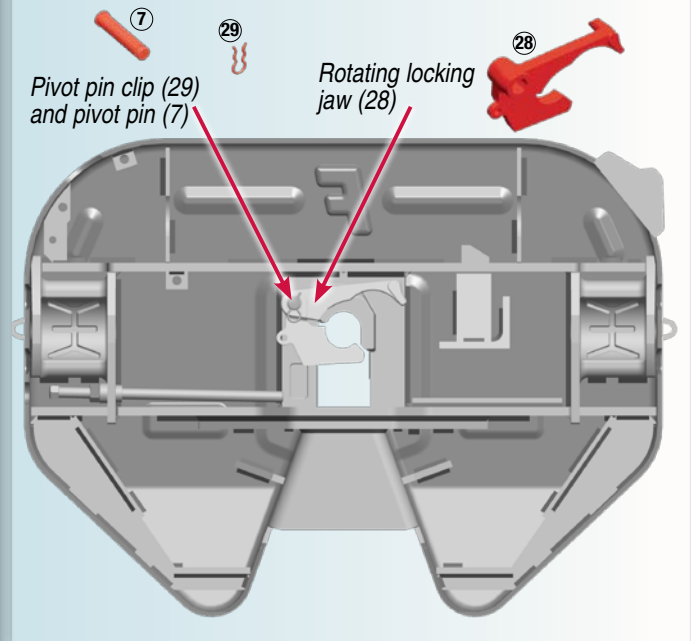

Note: DO NOT discard the locking wedge. Please refer to the Ultra LT product enhancement form on back for further instructions.

Refer to exploded view of assembly on page 2 to identify item number and parts.

Adequate lubrication should be used

1. Assemble the provided washer and pivot pin

With the fifth wheel raised, insert the long pivot pin (item 7) into the fifth wheel, through the rotating jaw (item 28), the newly provided washer (item 34) and then through the cover plate. Note: Make sure the notched portion of the pivot pin is inserted into the fifth wheel first and that the newly provided flat washer is located between the boss of the rotating jaw and the cover plate (see figure 1 below). Secure the pivot pin in place with the pivot pin clip (item 29). **Ensure that the jaw rotates freely about the pivot pin.**

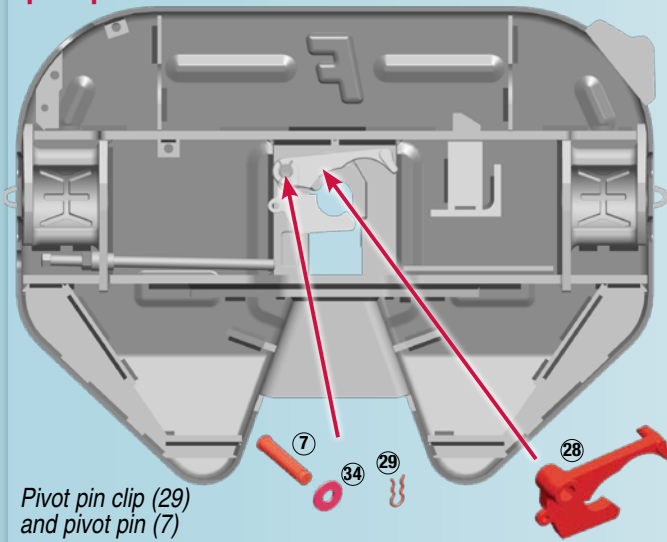

Ensure that the newly provided flat washer is located between the boss of the rotating jaw and the cover plate as shown (figure 1).

Rotating locking jaw (28) New 3/4" flat washer (item 34) Cover plate Pivot pin clip (29)

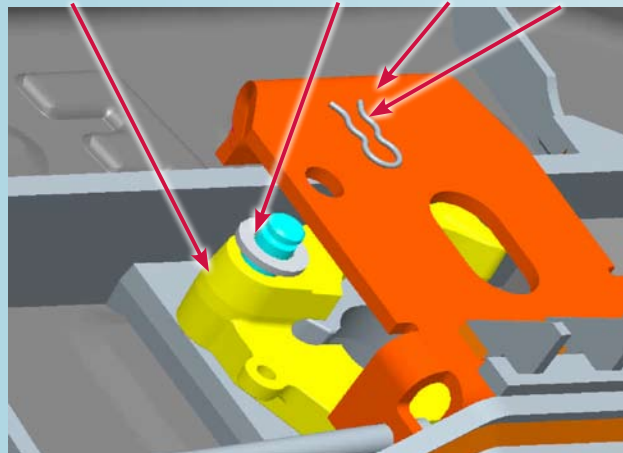
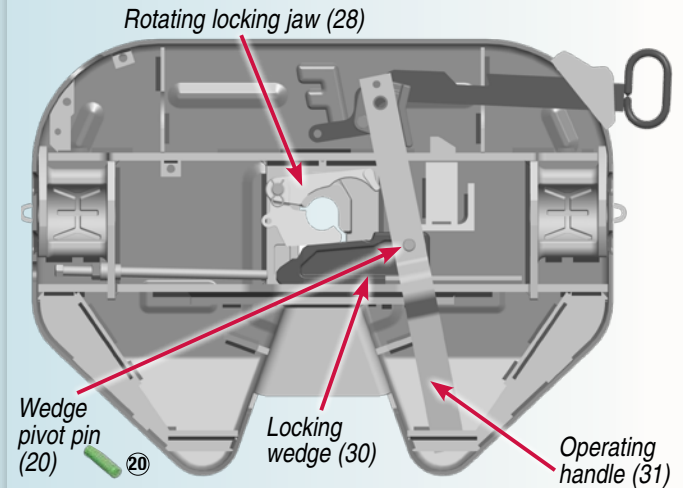

Figure 1

2. Insert new wedge and handle

Insert the wedge pivot pin (item 20) into the newly provided locking wedge (item 30) after applying a light coat of grease. Insert the locking wedge into the wheel. Slide the locking wedge in behind the rotating locking jaw (item 28). Now slide the locking wedge back toward the outside of the wheel. This will assist in installing the operating handle. Insert the end of the operating handle (item 31) into the slot at the bottom of the fifth wheel and over the wedge pivot pin. Rotate the operating handle towards the center of the fifth wheel. This will slide the locking wedge behind the locking jaw.



Refer to exploded view of assembly on page 2 to identify item number and parts.

3. Attach the operating handle to the locking wedge

Attach the operating handle (item 31) to the locking wedge by reusing the flat washer (item 32) and the newly provided cotter pin (item 33) to secure the connection.

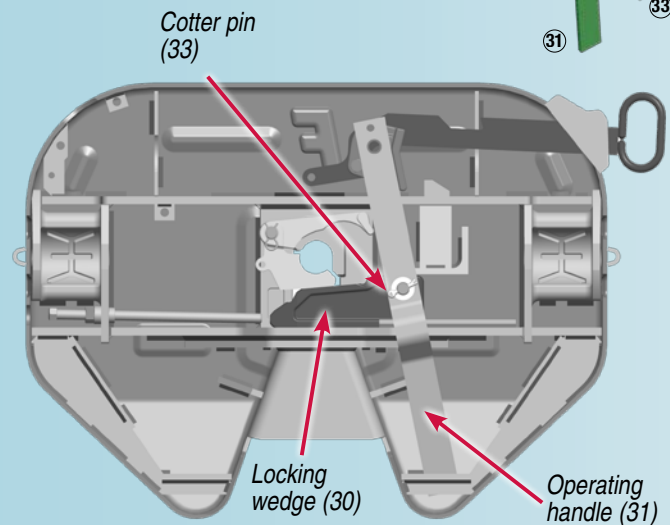

4. Attach the secondary lock to the operating handle

Attach the secondary lock (item 21) to the operating handle (item 31) using the newly provided lock nut (item 25) with the flat washer and spacer (items 23 & 24).

Ensure that the secondary lock rotates freely about the secondary lock bolt.

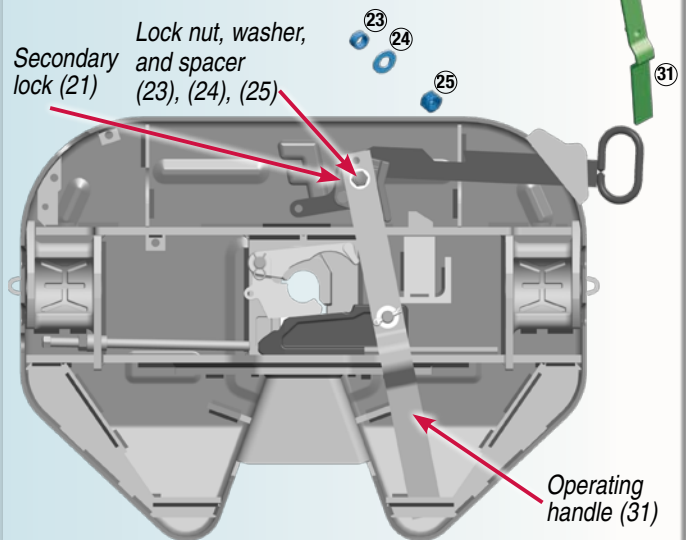

5. Attach the springs

Make sure the fifth wheel is completely closed. Attach the jaw spring (item 27) to the rotating jaw. Now install main springs (items 26) to the pull handle and operating handle.

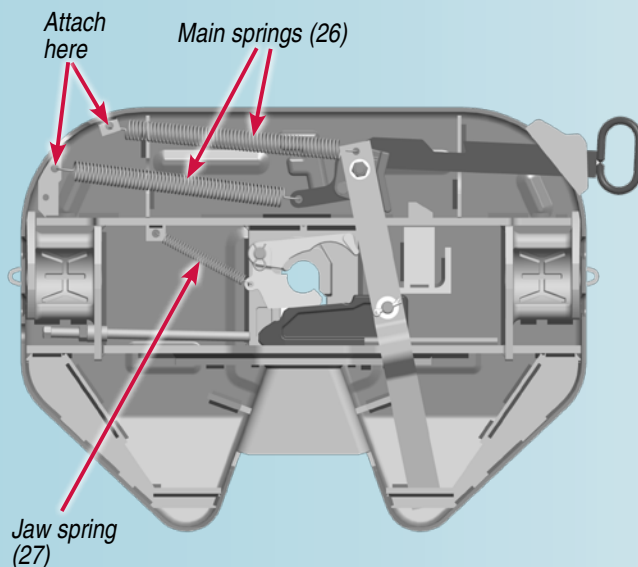

6. Adjust the fifth wheel

Open the fifth wheel, insert a 2" kingpin and close the wheel. Ensure that the fifth wheel has completely closed. Turn the adjustment rod (item 1) clockwise (inward) until it contacts the end of the locking wedge. Now turn the adjustment rod clockwise (inward) an additional 2-1/2 revolutions. This will give the recommended 0.5 mm (.02") running clearance. Tighten the adjuster rod jam nut (item 2). **The fifth wheel should operate freely and smoothly without binding or interference.**

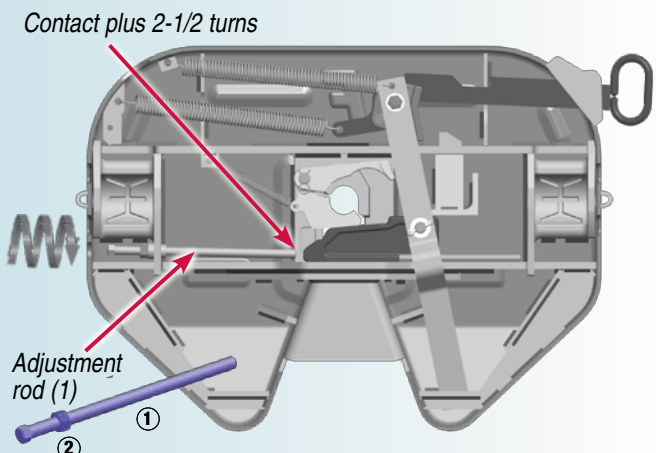

Final assembly steps

Reassemble the fifth wheel to the lower mount assembly to complete the procedure. Use the newly provided 3/16" x 1" cotter pins to secure the retainer pins on each side of the fifth wheel.

Please refer to the instructions on the following Ultra LT product enhancement form (back) for recording information that must be submitted to Fontaine Fifth Wheel for every vehicle serviced. If any problems are encountered during the rework please contact Fontaine Technical Support for assistance.

Serial number location for Ultra LT

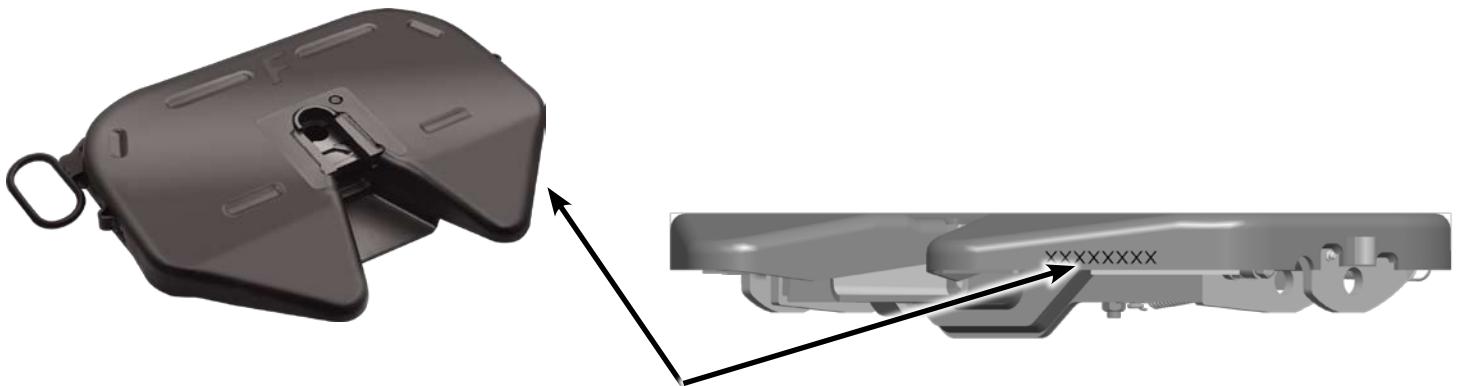

Serial number located on right side of fifth wheel skirt.
Note: position 5 and 6 of the serial number indicates the year built.

The serial number is necessary to complete form on back.

Ultra LT product enhancement form



Instructions:

- A completed form is required for every truck that has the Ultra LT product enhancement performed
 - For Ultra LT serial number location see page 7
- Please do not discard the locking wedge! Reuse the kit box and apply the prepaid return label to send the used parts back to Fontaine Fifth Wheel. If multiple used kit boxes need to be returned (ten or more), please contact our technical support department
 - Place a copy of the completed form in the used kit box so the used parts can be properly identified
 - Parts should not be returned collect. Please use the prepaid label or contact Fontaine Fifth Wheel for shipping instructions
- Completed form(s) must also be faxed, emailed or mailed to Fontaine Fifth Wheel
 - Fax: 800.445.6130 or 205.655.9981
 - Email: ULPE@fifthwheel.com
 - Mail: Fontaine Fifth Wheel, Attn: Product Enhancement
7475 Commerce Circle
Trussville, AL 35173
- **Fontaine Fifth Wheel will require the used locking wedge to be returned with a completed form for each replacement before any labor compensation can be administered**
- Standard rate time (SRT) for this work is .75 hrs (45 min)
- If you have any additional questions, please contact Technical Support
 - Phone: 800.874.9780 or 205.661.4900
 - Email: ULPE@fifthwheel.com

| | | | | | |
|-------------------------------|---------------------------------------|--------------------------------|-------------------------------|-----------------------------------|--|
| Date of work: | | | | | |
| Fleet name: | | | | | |
| Facility performing the work: | | | | | |
| Address: | | | | | |
| City: | | State: | | Zip: | |
| Key contact: | | | | | |
| Fifth wheel serial number: | _____ | | | | |
| Truck number: | | | | | |
| OEM: | <input type="checkbox"/> Freightliner | <input type="checkbox"/> Volvo | <input type="checkbox"/> Mack | <input type="checkbox"/> Navistar | <input type="checkbox"/> Kenworth <input type="checkbox"/> Peterbilt |
| VIN number: | | | | | |
| Mileage | | | | | |

