

Fontaine Fifth Wheel Ultra iT

Rebuild Procedures

- Disassembly
- Assembly
- Adjustments

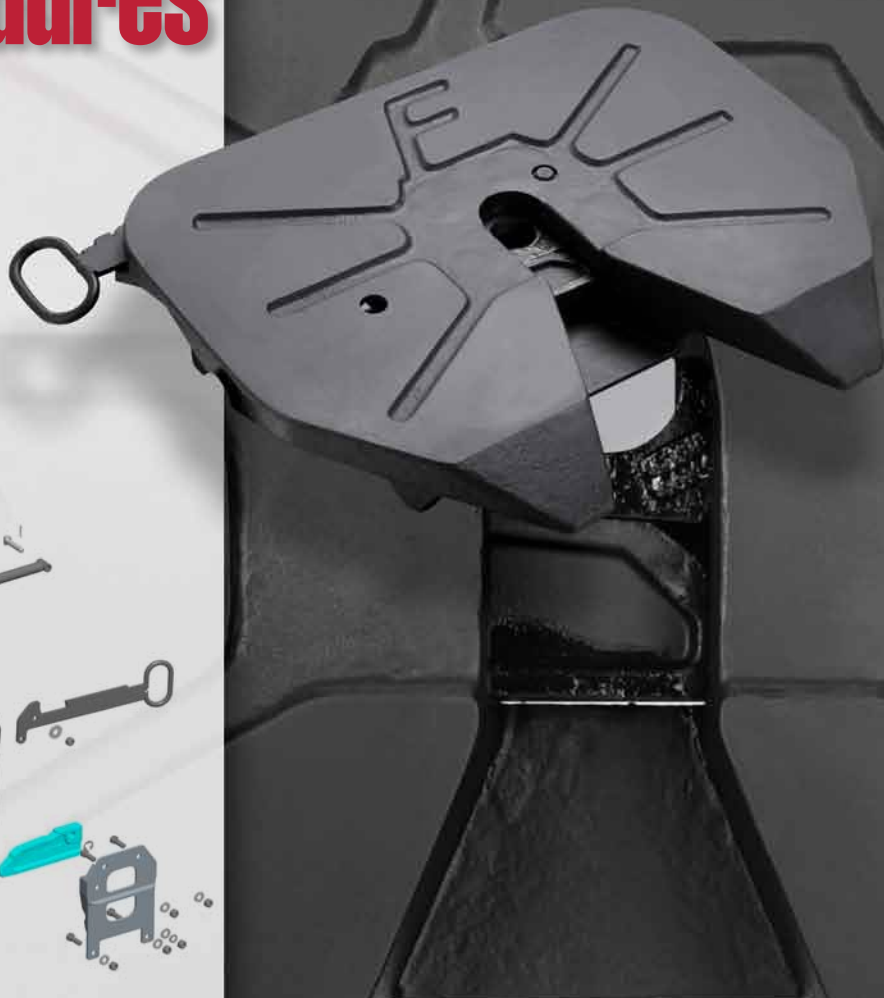
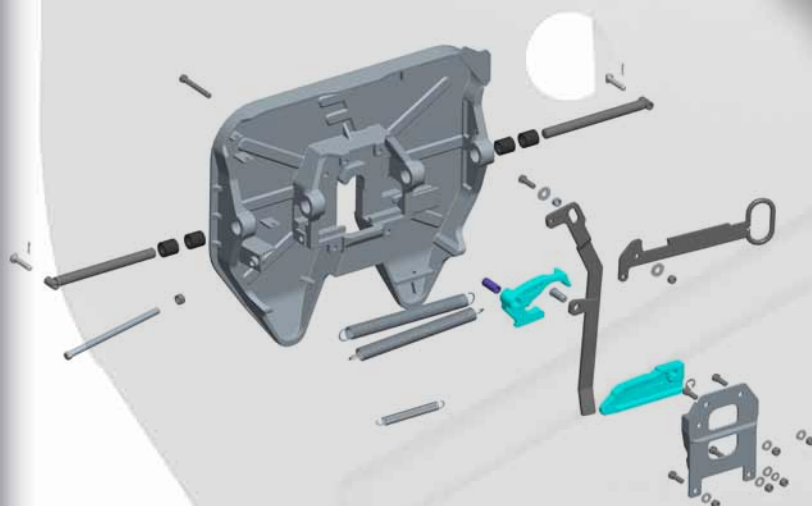

FONTAINE[®]
PARTS CONNECTION

www.fifthwheel.com • 800-874-9780

Refer to exploded view of assembly on page 6-7 to identify item number and parts.

Degrease fifth wheel before installing new parts

1. Set the fifth wheel in the closed position

To do this, rotate the locking jaw (item 9) towards the front of the fifth wheel with a screw driver of adequate length to keep hands and fingers out of the throat of the wheel. This will partially close the wheel. Now pull out on the pull handle (item 10) a small amount and complete the rotation of the jaw toward the front of the wheel. Allow the pull handle to go in slowly for the wheel to completely close.

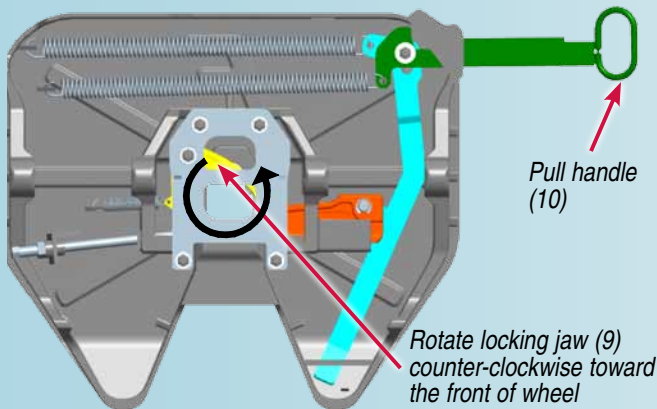

2. Remove the jaw spring

First remove the two main springs (item 16) from the wheel followed by the jaw spring (item 17). Once the main springs are removed the wheel can be opened again to release tension from jaw spring and ease removal.

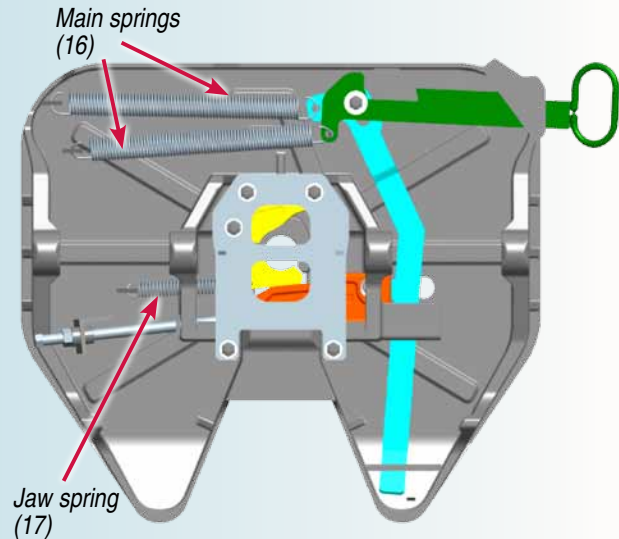

3. Remove cover plate

First remove the lock nut (item 21), lock washer (item 25), and flat washer (item 24) from the pivot bolt (14). Next remove the 4 lock nuts (item 21), and 4 flat washers (item 24) from the cover plate bolts (22). Remove cover plate (item 12). NOTE: use an open-ended 3/4" wrench to hold the bolt heads for disassembly.

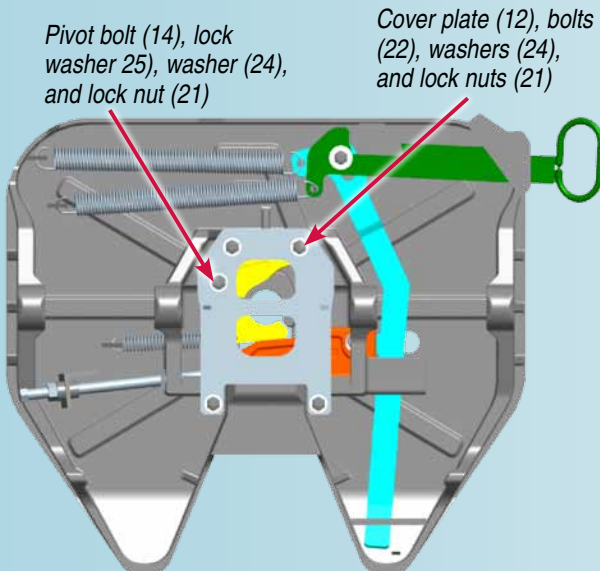

4. Remove rotating jaw and pull handle

First remove the rotating locking jaw (item 8), associated bolt (item 23) and jaw spacer bushing (item 13). Next remove bolt (item 18), spacer bushing (item 20), 2 washers (item 19), and lock nut (item 21) from pull handle (item 9). Remove pull handle through slot in skirt of fifth wheel.

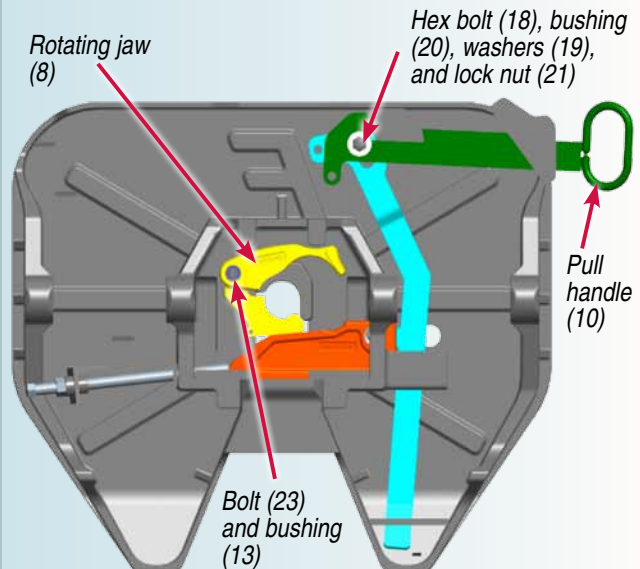

Refer to exploded view of assembly on page 6-7 to identify item number and parts.

5. Back out adjustment rod and remove lock bar pin

First back out the adjustment rod (item 5) approximately 2" by loosening nut (item 6) and turning counter-clockwise. This will eliminate interference when removing and installing the lock bar (11). Next slightly open operating handle (9) to place lock bar pin (item 14) over the hole in top plate. Remove E-clip (item 15) and push lock bar pin (14) through hole.

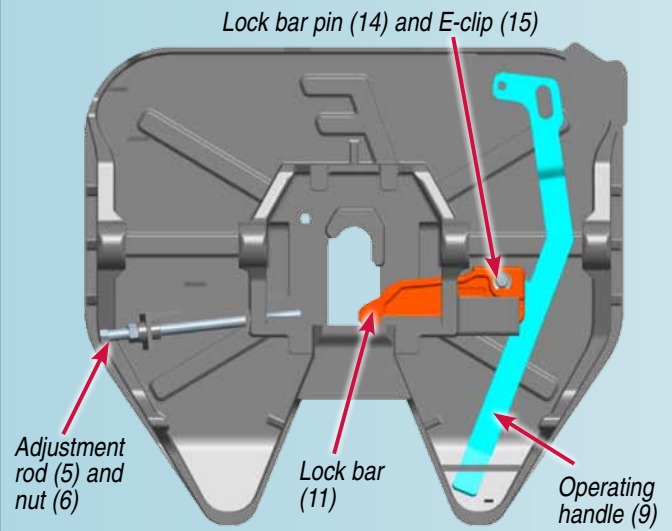

6. Remove lock bar and operating handle

Slide lock bar (item 11) towards center of wheel and lift out to remove. Open operating handle (item 9) and slide out of toe guide to remove handle from wheel. If necessary remove and replace adjustment rod (item 5) and adjustment rod lock nut (item 6).

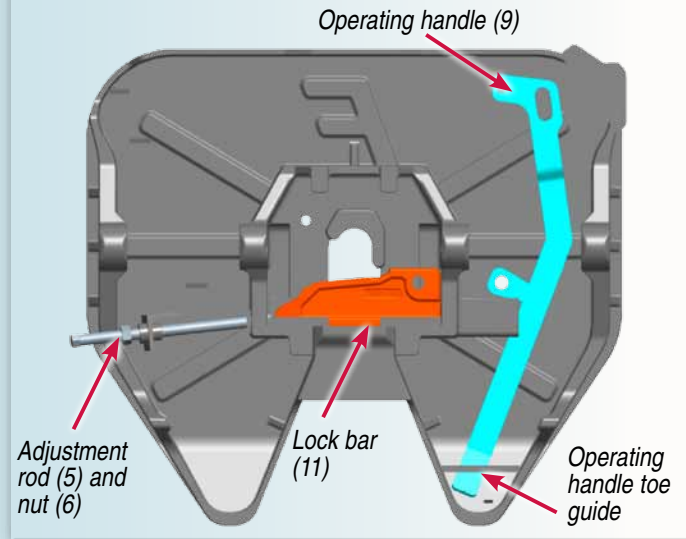

Refer to exploded view of assembly on page 6-7 to identify item number and parts.

Adequate lubrication should be used

Before rebuilding the assembly, check to make sure that there are no cracks in the crossmembers or other components. Also check bracket pin holes to ensure they are not overly worn (pins should fit snugly). Refer to exploded view of assembly on page 6-7 to identify item numbers and parts.

1. Insert lock bar and operating handle

If adjustment rod (item 5) and lock nut (item 6) were removed or replaced reinstall partially leaving room for lock bar (11). Apply grease to lock bar and lock bar guide. Install lock bar in the center of wheel and slide towards hole in top plate. Install operating handle (item 9) into toe guide.

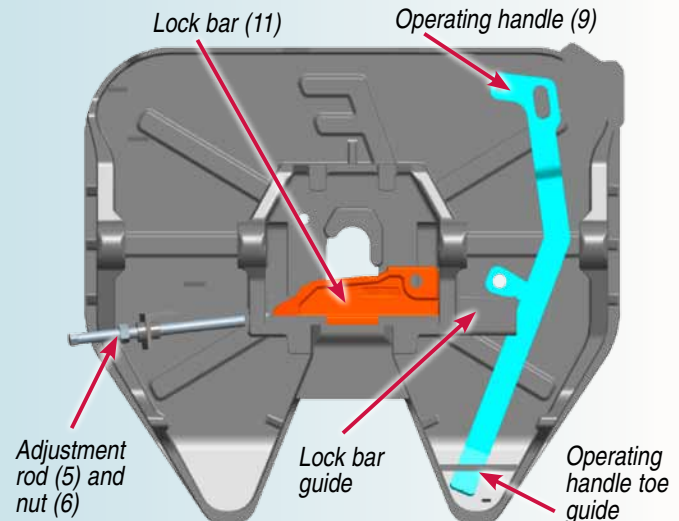

2. Install lock bar pin

Align holes in lock bar (item 11) and operating handle (item 9) with hole in top plate casting. Install new lock bar pin (item 14) through hole in top plate into lock bar and operating handle after applying a light coat of grease to contact surfaces. Insert new E-clip (item 15) on to lock bar pin and ensure connection moves freely.

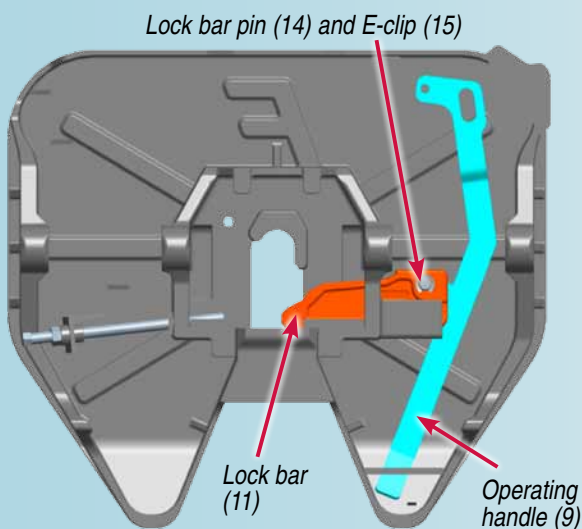

3. Install rotating jaw and pull handle

Install a new rotating jaw bolt (item 23) from top side of top plate and new rotating jaw spacer bushing (item 13) over bolt. Place new rotating jaw (item 8) over spacer. Next slide pull handle (item 10) through slot in skirt of fifth wheel and install new bolt (18), spacer bushing (20), washers (19), and lock nut (item 21).

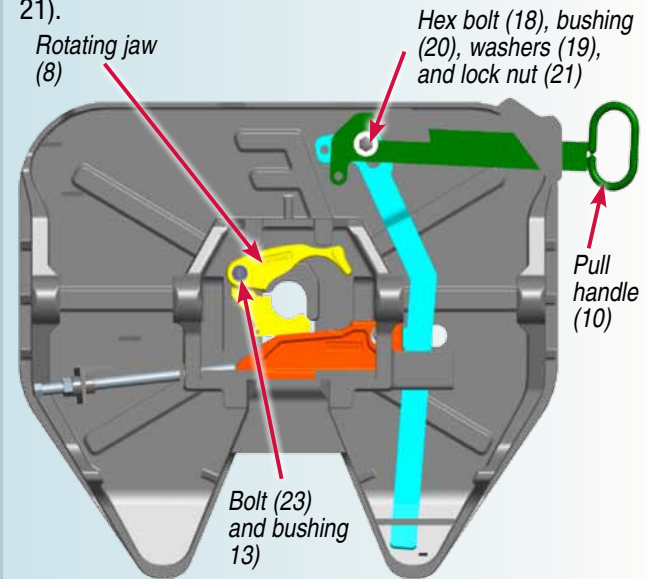

Refer to exploded view of assembly on page 6-7 to identify item number and parts.

4. Install cover plate

Apply grease to moving components and place cover plate (item 12) over components being careful to align pivot bolt (14). Install the flat washer (item 24), lock washer (item 25), hex nut (item 21) onto pivot bolt. Next install the 4 hex bolts (22) through the frame and cover plate and install 4 flat washers (24) and 4 lock nuts (21) onto the 4 hex bolts. NOTE: Insert the top two bolts prior to cover plate for ease of installation. Nuts should be on cover plate side (visible after installation). Use an open-ended $\frac{3}{4}$ " wrench to hold the bolt heads for assembly.

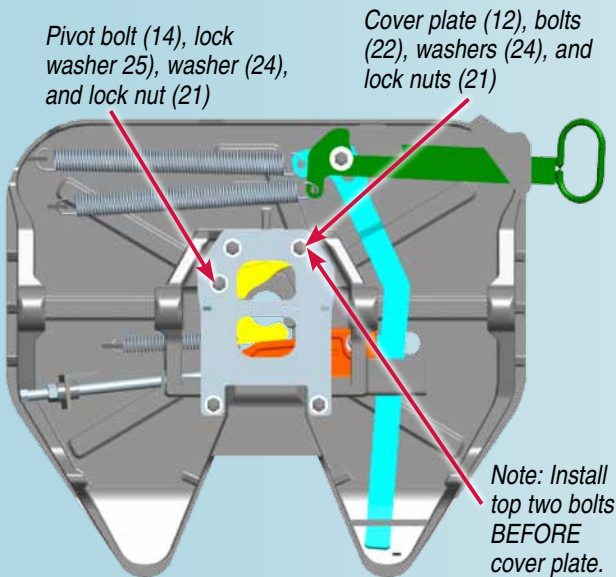

5. Install springs

First install jaw spring (item 17) into the wheel followed by the two main springs (item 16). The jaw can be rotated open to install jaw spring and then closed with pull handle to install main springs.

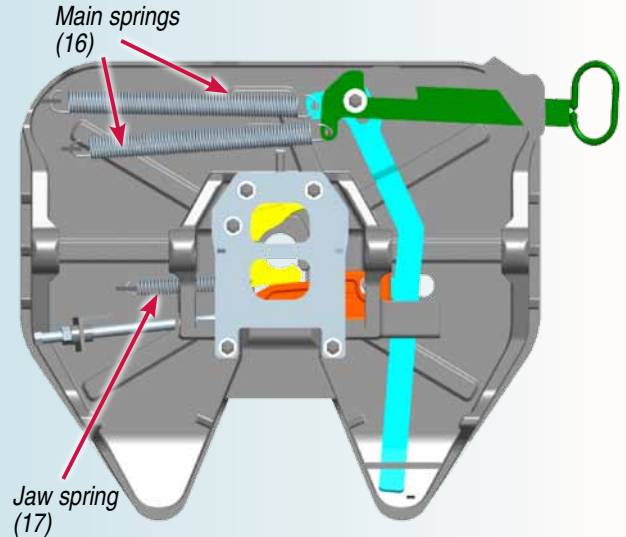

6. Adjust fifth wheel

Open the fifth wheel, insert a 2" kingpin and close the wheel. Turn the adjustment rod (item 5) clockwise (inward) until it contacts the end of the lock bar (item 11). Now turn the adjustment rod clockwise (inward) an additional 2-1/2 complete revolutions. This will give the recommended 0.525 mm (.02") running clearance. Tighten the adjuster rod nut (item 6). The fifth wheel should operate freely and smoothly without binding or interference.

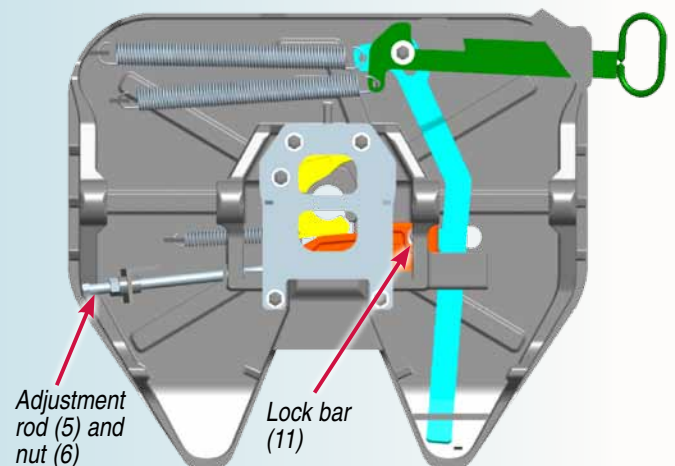

Ultra LT rebuild diagram

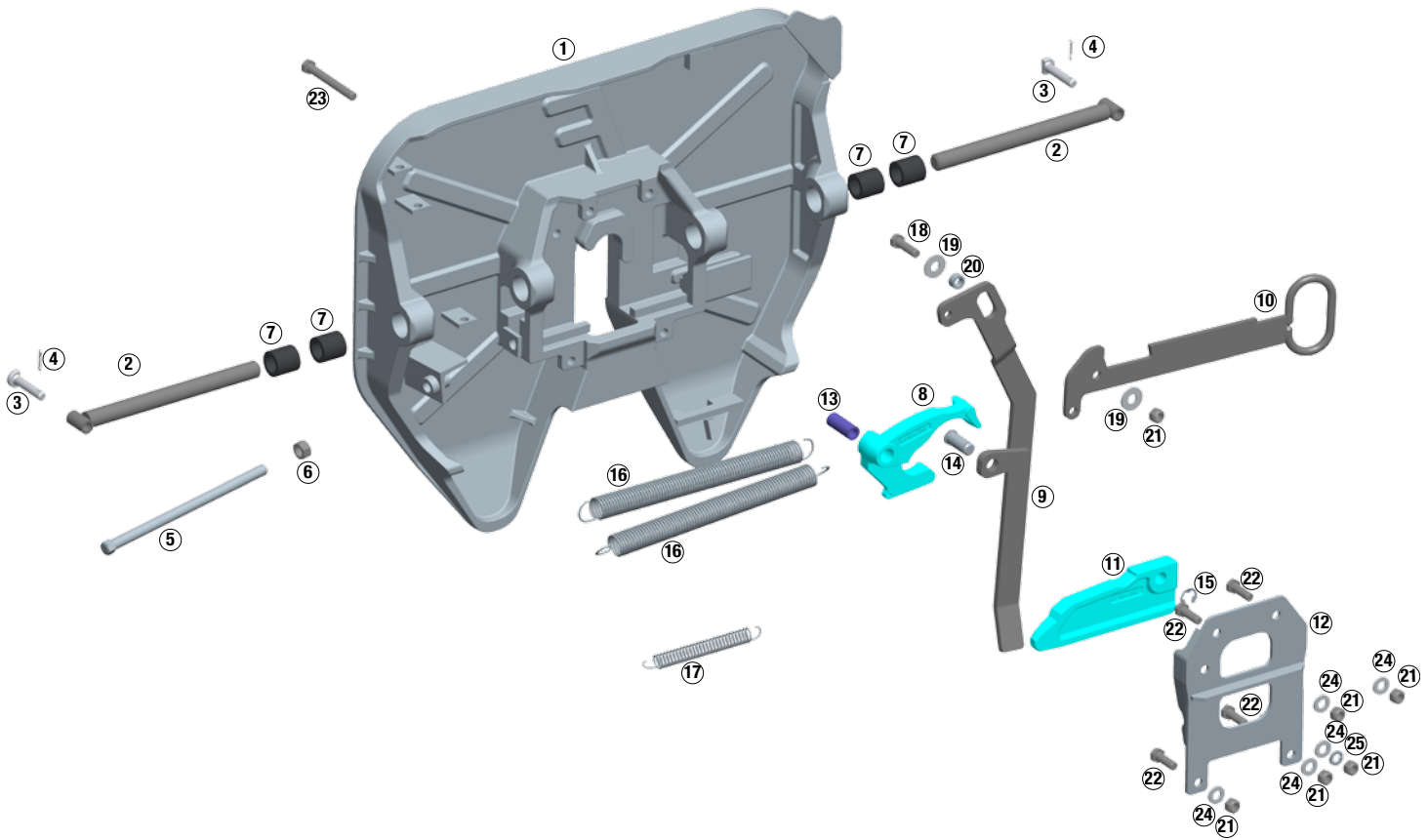

Repair kit (KIT-UIT-L)

Item	Description	Quantity
⑧	Rotating locking jaw	1
⑪	Locking bar	1
⑯	Main spring	2
⑰	Jaw spring	1
⑬	Jaw spacer bushing	1
⑭	Locking bar pivot pin	1
⑮	Pivot pin e-clip	1
⑳	Hex head bolt, 1/2"-13 X 4.25"	1
㉕	Washer, lock, 1/2"	1
㉔	Washer, small, hardened, 1/2"	5
㉑	Hex lock nut, 1/2"-13	5

Spring kit (KIT-SPR-UIT)

⑯	Main spring	2
⑰	Jaw spring	1

Pull and operating handle kit (KIT-HDL-UIT-L)

Item	Description	Quantity
⑨	Operating handle	1
⑩	Pull handle	1
⑪	Locking wedge pivot pin	1
⑮	Pivot pin e-clip	1
⑱	Hex head bolt, 1/2"-13 X 1.75	1
㉒	Spacer bushing	1
⑲	Washer, large, hardened, 1/2"	2
㉑	Hex lock nut, 1/2"-13	1

Adjuster rod kit (KIT-ROD-UL)

⑤	Adjustment rod	1
⑥	Adjustment rod nut	1

Cover Plate kit (KIT-COV-UIT-L)

Item	Description	Quantity
⑫	Cover plate	1
㉓	Hex head bolt, 1/2"-13 x 4.25"	1
㉕	Lock washer, 1/2"	1
㉔	Washer, small, hardened, 1/2"	5
㉑	Hex lock nut, 1/2"-13	5

Mounting pin kit (KIT-PIN-UIT)

⑦	Composite bushings	4
②	Bracket pin	2
③	Bracket retainer pin	2
④	Cotter pin	2

Ultra LT rebuild diagram key

Item	Description	Quantity
①	Ultra iT fifth wheel weldment	1
②	Bracket pin	2
③	Bracket retainer pin	2
④	Cotter pin	2
⑤	Adjustment rod	1
⑥	Adjustment rod nut	1
⑦	Composite bushing	4
⑧	Rotating locking jaw	1
⑨	Operating handle	1
⑩	Pull handle	1
⑪	Locking bar	1
⑫	Cover Plate	1
⑬	Jaw spacer bushing	1
⑭	Locking bar pivot pin	1
⑮	pivot pin e-clip	1
⑯	Main spring	2
⑰	Jaw spring	1
⑱	Hex head bolt, 1/2"-13 x 1.75"	1
⑲	Washer, large, hardened, 1/2"	2
⑳	Spacer bushing	1
㉑	Hex lock nut, 1/2"-13	6
㉒	Hex head bolt, 1/2"-13 x 1.5"	4
㉓	Hex head bolt, 1/2"-13 x 4.25"	1
㉔	Washer, small, hardened, 1/2"	5
㉕	Washer, lock, 1/2"	1



Fontaine Parts Connection • 7574 Commerce Circle • Trussville, AL 35173
800-874-9780 • Fax: 205-655-9982

www.fifthwheel.com