

# NEWS RELEASE

FONTAINE

For Immediate Release

Media Contact:  
Kristen Simpson  
Simpson Communications, LLC  
(216) 991-4297  
simpsoncomm@aol.com

## Say “Snow Long” to Frozen Fifth Wheels

*Fontaine International Offers Fifth Wheel Maintenance Tips for Cold Weather*

**Irondale, Ala. (Sept. 18, 2008)** – Leading fifth wheel manufacturer Fontaine International recommends that fleets and owner operators take special precautions during cold weather to ensure that their trucks’ fifth wheels continue to operate properly.

“Many lubricants become thick and binding in low temperatures, and ice and sludge can build up on the underside of fifth wheel plates,” says Terry Mennen, Fontaine International vice president of sales and marketing. “As a result, parts may get stuck or move sluggishly, making the fifth wheel difficult to operate. The jaw and wedge may even be prevented from closing properly.”

In preparation for winter weather, Fontaine recommends thoroughly cleaning the fifth wheel latching mechanism using a suitable cleaner or degreaser to ensure that all parts can travel freely. Grease and road grime also should be removed from the slider mechanism of fifth wheels equipped with sliders. If temperatures are already consistently below freezing and the fifth wheel suffers from a large buildup of grease and grime, Fontaine recommends a complete steam cleaning.

Once the fifth wheel is clean, it should be thoroughly lubricated. Grease the jaw and wedge on the top and bottom. Separate the jaw and wedge with a large screwdriver and distribute the grease along the full length of the mating surfaces. Open and close the fifth wheel several times to further distribute the grease.

Fontaine suggests using a Moly-based lubricant such as Mobilgrease Moly 50 or equivalent when applying lubricant for cold weather. Equipment that is driven in regions with extreme and/or prolonged freezing temperatures may benefit from lubrication with a less viscous substance, such as 90-weight oil, to help ensure the proper movement of the latching mechanism. Fontaine recommends contacting the lubricant manufacturer for guidelines on the mixing compatibility of any lubricant.

Videos, technical bulletins and instruction handbooks for all necessary maintenance and repair of Fontaine fifth wheels are available at no

-more-

Say "Snow Long"  
Add 1

charge by calling (800) 874-9780. For more information about Fontaine's full line of fifth wheels and replacement parts from Fontaine Parts Connection, visit [www.fifthwheel.com](http://www.fifthwheel.com).

### About Fontaine

Based in Irondale, Ala., Fontaine International, Inc. is the world's largest fifth wheel manufacturer. It has ISO 14001 registered manufacturing facilities worldwide.

Fontaine is a Marmon Highway Technologies (MHT) company. MHT companies support the transportation industry worldwide with a wide range of high-quality products and services.

MHT companies are members of The Marmon Group, an international association of more than 125 business units that operate independently within diverse business sectors. Member companies have combined revenues of \$7 billion. The Marmon Group is a Berkshire Hathaway company.

#

*Editor's Note: Please see illustration.*

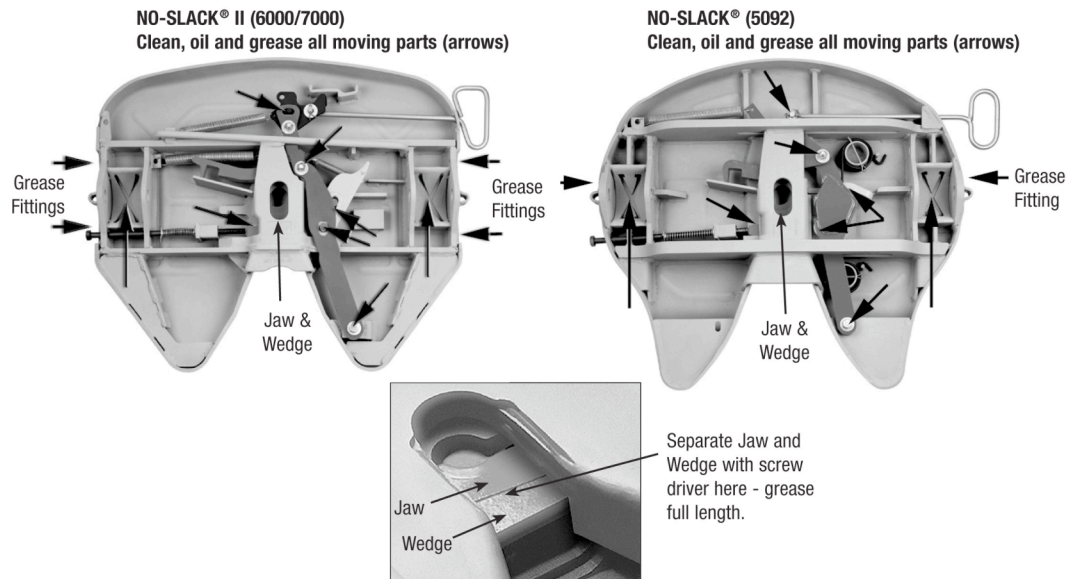

*Caption: Fontaine International recommends thoroughly cleaning and lubricating fifth wheels in preparation for cold winter temperatures.*

0650-1016  
9/18/08